



**TORQUE ARM CONVERSION INSTALLATION INSTRUCTIONS
TAS010 - 1968-1974 Nova 10 BOLT**

Please take note before proceeding with this installation:

- *This product may interfere with certain exhaust kits. Exhaust crossovers are not compatible with this torque arm suspension. In some circumstances, it may be necessary to fabricate a custom exhaust for proper clearance.*
- *While not necessary, a heavy duty cast aluminum differential cover is recommended with this kit. These covers are more structural in nature than the stamped steel OE unit and will distribute the load across the differential, further strengthening the assembly.*

TOOLS REQUIRED:

- 3/8" and 1/2" drive ratchets
- 1/2", 5/8" deep, 9/16", 3/4" deep, 15/16" and 1-1/8" sockets
- Pry-bar
- 3/8" Allen wrench

ADDITIONAL ITEMS REQUIRED:

- RTV gasket silicone
- Gear oil

HARDWARE CHECKLIST:

You should have 2 hardware packets in your BMR Torque Arm Conversion Kit. Please check contents of both packets before proceeding with the installation.

HP124 HARDWARE PACKET

QUANTITY	DESCRIPTION
2	1/2 x 2.5 Grade 8 bolt
4	1/2 x 3 Grade 8 bolt
4	1/2 x 3.25 Grade 8 bolt
1	1/2 x 4 Grade 8 bolt
2	1/2 x 5 Grade 8 bolt
17	1/2 flat washer, SS
13	1/2 poly lock nut
2	3/8 x 3.75 Grade 8 bolt
2	3/8 poly lock nut
2	3/8 flat washer, SS
2	5/8 x 4 Grade 8 bolt
2	5/8 poly lock nut
4	5/8 flat washer, SS
2	5/8 flat washer
4	#14 x 3/4" self-tapping screw

CONTINUED



TAS010 TORQUE ARM CONVERSION INSTALLATION INSTRUCTIONS (Continued)

HP130 HARDWARE PACKET

QUANTITY	DESCRIPTION
4	5/16 x 2.25 stud
8	5/16 x 2 Grade 8 bolt
12	5/16 flat washer
4	5/16 poly lock nut
4	3/4 x 2 Grade 8 bolt
4	3/4 lock washer
5	1/2 x 3.25 Grade 8 bolt
1	1/2 x 4 Grade 8 bolt
4	1/2 x 4.5 Grade 8 bolt
10	1/2 flat washer, SS
8	7/16 flat washer
10	1/2 poly lock nut
2	5/8 x 3.5 Grade 8 bolt
2	5/8 lock washer
2	5/8" SS large diameter washer

CROSS-MEMBER INSTALLATION:

- 1) Lift the vehicle and support with stands under the rocker panel pinch seams (Do not place stands under the sub-frame).
- 2) Remove the exhaust system.
- 3) Using a 15/16" socket, remove the rear two body mount bolts.
- 4) Remove the OE rubber body mount bushings. They are composed of an upper and lower bushing that "sandwich" the sub-frame together in the middle. **NOTE:** a pry-bar may be necessary to get the sub-frame low enough to remove these bushings.
- 5) Once the OE bushings have been removed, inspect the sub-frame for rust damage. This is a common area susceptible to rust and if the mounting point is compromised, it needs to be repaired before proceeding with the installation.

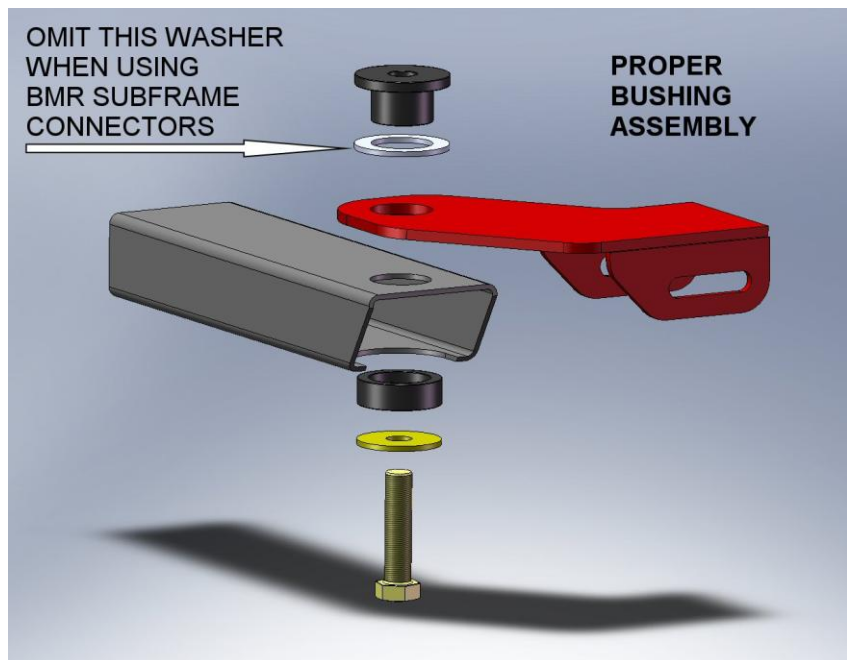



CROSS-MEMBER INSTALLATION (Cont.)

- 6) Begin with the driver's side. Assemble the driver's side frame mount, billet body mounts and washer (if necessary) as shown in the image above. If you are using a sub-frame connector that mounts around the body bushing, omit the supplied aluminum spacer washer shown on the previous page.
- 7) Thread the supplied 5/8" bolt, large stainless washer and lock washer into the body and snug the bolt just enough to allow the frame bracket to rotate around the axis of the bushing.
- 8) Repeat steps 4-7 for the passenger side. At this stage both mounts should be installed and you can mount the cross-member. Lift the cross-member into place and insert the supplied 1/2" x 4.5" bolts, (8) stainless washers, and nuts.
- 9) Tighten the body mount bolts to 150 ft/lbs.
- 10) Center the cross-member to the driveshaft then tighten the (4) cross-member bolts.



TORQUE ARM INSTALLATION INSTRUCTIONS:

- 1) Remove the differential drain plug or loosen the cover bolts to drain the gear oil from the differential.
- 2) If it was not necessary to remove the cover previously, remove the 10 bolts from the differential cover and remove the cover.
- 3) Using a gasket scraper, remove all gasket material from the cover and the differential.
- 4) Thread the four supplied 5/16" studs into the differential at the four corners. All studs should bottom out and should thread in to the same depth. If not, run a 5/16-18 bottoming tap through the holes in the differential.





TORQUE ARM INSTALLATION INSTRUCTIONS (Cont.)

- 5) Apply a thin bead of RTV Black or Grey gasket silicone onto the differential gasket mating surface. Install one of the supplied gaskets.
- 6) Apply another thin bead of RTV on the exposed gasket surface. Position the BMR torque arm mounting plate onto the rear end with the torque arm mounting points facing forward as in **IMAGE 1** on the previous page.
- 7) Apply another thin bead of RTV onto the BMR torque arm mounting plate at the gasket mating surface then install the other supplied gasket.
- 8) Apply another thin bead of RTV onto the exposed gasket surface then re-install the differential cover.
- 9) Place one of the supplied 5/16" washers and 5/16" poly-lock nuts onto each stud and then insert the (6) 5/16" bolts and washers into the remaining holes. Tighten all ten in a star shaped pattern. Snug each one first then torque them to 20-25 ft/lbs.
- 10) Mount the torque arm to the differential mounting plate using one of the supplied 1/2" x 3.25" bolts. Place a stainless washer under the nut and temporarily thread it finger tight. (See **IMAGE 2**)
- 11) Insert the front telescoping bushing into the torque arm with the grease fitting pointing downward.
- 12) Lift the front of the torque arm up until the bushing hole lines up with the mount on the torque arm cross-member. Insert the supplied 1/2" x 4" bolt, nut and stainless washer. Tighten to 90 ft/lbs. (**Image 3**)
- 13) Using either a 5/8" or 3/4" deep socket, slightly loosen the leaf spring mounts on the rear end. They should be loose enough to allow the rear end to rotate slightly.
- 14) Position one of the support braces up against the torque arm as shown in **Image 5**. Place a lock washer over two of the supplied 3/4" x 2" bolts and thread them into the support brace, through the BMR differential mounting plate. Leave the bolts loose.

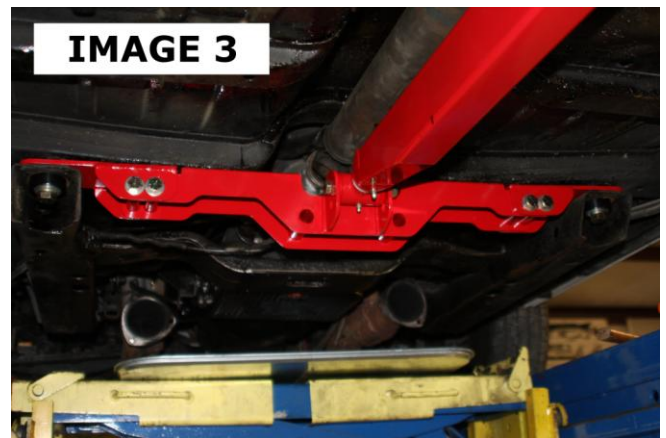



TORQUE ARM INSTALLATION INSTRUCTIONS (Cont.)

- 15) Repeat step 18 for the other side.
- 16) Loosen the jack screw from the bottom side of the torque arm using a 3/8" Allen wrench. **(Image 6)** Loosen it as far as possible to provide clearance between the rear end and the torque arm. This will be adjusted in a later step.
- 17) Place washers over the supplied 1/2" x 3.25" bolts and insert them into the four holes on the torque arm. It is typical for these holes not to align properly and is necessary to use a pry-bar to pivot the rear end until all four bolts slide through. *NOTE: this step is somewhat difficult and it may seem that the parts do not fit together however all assemblies are pre-fit and tested before shipping to insure proper fitment.*
- 18) Once all four bolts are through the assembly, place another washer and a nut on each one and finger-tighten them.
- 19) Using a 1-1/8" socket, tighten the four 3/4" bolts on the rear of the differential mounting plate to 100 ft/lbs.



- 20) The following step involves setting the driveline angle. While this process is actually very simple, it is difficult to explain so we have provided detailed instructions and examples below. Driveline angle is the difference between the pinion angle and the driveshaft angle. Zero degrees means there is no angle and the pinion and driveshaft are straight as viewed from the side. If the angle is negative, the driveshaft and the rear-end will form a "V". If it is positive, the driveshaft and rear-end will form an "upside down ^". For street driving this angle should be between 0 and -3 degrees to promote long u-joint life. Begin by placing the supplied angle finder on the rear BMR mounting plate as shown in **Image 7** and record the reading. Take your reading from the drivers' side of the car. Since the rear cover is 90 degrees perpendicular to the pinion, this angle represents the angle of the pinion gear minus 90 degrees. Now place the angle finder on the driveshaft (**Image 8**) and record the reading





TORQUE ARM INSTALLATION INSTRUCTIONS (Cont.)

from the drivers' side of the car. This angle represents the driveshaft angle. The goal angle to reach is a 2 degree difference between the two recorded angles. For example, our test car used for these instructions had the following readings:

The rear angle on the differential mounting plate was 88 degrees. You need to subtract 90 degrees from this to get your pinion angle, resulting in -2. The driveshaft angle just happened to be at 0 degrees. The difference between these two angles is -2, right where we want to be. If your resulting angle is anywhere between 0 and -3, it is an acceptable angle. To adjust this angle you can use the jack screw located at the back of the torque arm to raise or lower the pinion simply by turning the screw (refer back to **Image 6**). The screw will



turn against the rear end, pushing it upward. If the angle is off excessively, use a pry-bar to rotate the rear end until the angle is close enough to use the jack screw.

- 21) Once the driveline angle is set, tighten all 5 cross-bolts to 90 ft/lbs.
- 22) Make sure the jack screw is touching the differential housing and then tighten the jam-nut located on the jack screw.
- 23) Re-tighten the leaf spring bolts.
- 24) Fill the differential with gear lube.
- 25) Grease both of the front grease fittings with a silicone or other synthetic based lube.



TAS010 TORQUE ARM CONVERSION INSTALLATION INSTRUCTIONS TAS010 - 1968-1974 Nova 10 BOLT

Please take note before proceeding with this installation:

- *This product may interfere with certain exhaust kits. Exhaust crossovers are not compatible with this torque arm suspension. In some circumstances, it may be necessary to fabricate a custom exhaust to insure adequate clearance.*
- *While not necessary, a heavy duty cast aluminum differential cover is recommended with this kit. Cast covers are more structural in nature than the stamped steel OE unit and will distribute the load across the differential, further strengthening the assembly.*
- *A service lift, while not necessary, is recommended for this installation.*

TOOLS REQUIRED:

3/8" and 1/2" drive ratchets	9/16", 3/4" wrenches
3/8", 9/16", 3/4" and 1-1/8" sockets	Rubber mallet
Pry-bar	Drill
3/8" Allen wrench	Step bit or 1/2" and 3/4" drill bits
Jack stands	Hydraulic Jack
Grease gun with synthetic lube	Torque wrench
Welder (optional)	Plumb bob and tape measure

INSTALLATION:

This installation is the second part of the torque arm conversion process. It is assumed at this point that the installer has already installed the BMR Torque Arm and Torque Arm cross-member using the appropriate instruction sheets. Lift vehicle and support with stands under the frame, allowing the rear end to hang.

1. Remove the rear wheels/tires.
2. If the vehicle has exhaust installed, remove it at this time.
3. Remove the rear shocks. Using the OE shock bolts, bolt the supplied BMR shock plates over the factory shock holes as shown in **IMAGE 1**.
4. To gain adequate access for the upper cross-member installation, it is recommended that the fuel tank be removed. Drain the tank using a drill pump or siphon.
5. Support the tank and then remove the two mounting nuts using a 9/16" deep socket. Pull the tank support straps down, allowing the tank to be lowered.
6. Lower the tank far enough to access the fuel lines and electrical connectors. Disconnect and cap the fuel lines. Lower and remove the fuel tank.
7. Support the rear end with jack stands.



IMAGE 1

(CONTINUED)



TAS010 TORQUE ARM CONVERSION INSTALLATION INSTRUCTIONS (Continued)

8. Using a 5/8" or 3/4" socket, remove the leaf spring U-bolts on the rear end. **(IMAGE 2)**
NOTE: the image shown has aftermarket traction bars installed. Leaf spring mounts may appear slightly different in nature.
9. Using a 5/8" socket, loosen and remove the rear leaf spring shackle bolts. Loosen the upper shackle bolt at the frame and remove the shackles. **(IMAGE 3)**



10. Using a 9/16" socket, remove the (3) bolts on the front spring mount of each leaf spring. **(IMAGE 4)** *NOTE: the image shown had aftermarket traction bars installed. Front leaf spring eye may appear slightly different in nature.*
11. Once all bolts are removed, remove the leaf springs, leaving the rear end in its original position.
12. Once the leaf springs have been removed, loosen the bolts and remove the front spring pockets. **(IMAGE 5)**
13. Install the BMR trailing arms into the leaf spring pockets as shown using the provided 1/2" x 5" bolts. Place a stainless washer under the nut then tighten to 80 ft/lbs.
14. Re-install the spring pockets into the body as shown in **IMAGE 7**. Tighten the 3 spring pocket bolts to 30 ft/lbs.

TAS010 TORQUE ARM CONVERSION INSTALLATION INSTRUCTIONS (Continued)

15. Install the BMR control arm mounts onto the axle using the supplied U-bolts. The open portion of the mount should face forward as shown in **IMAGE 8** below. **NOTE:** You may omit the inner U-bolt and use the factory 7/16" carriage bolts, if preferred. Doing so will prevent brake line interference on the top of the axle. Tighten nuts to 60 ft/lbs.



16. Lift and insert the other end of the control arm into the axle brackets on the highest mounting hole and insert the supplied 1/2" x 3.25" bolts. Place a stainless washer under the nut but leave this connection loose until a later step. **NOTE:** it may be necessary to adjust the length of the control arms to match the holes in the control arm mounts. It may also be necessary to move the rear end forward or back to line the mounting holes up. If one trailing arm is adjusted, duplicate this procedure on the other arm and verify that they are equal in length before proceeding to the next step.

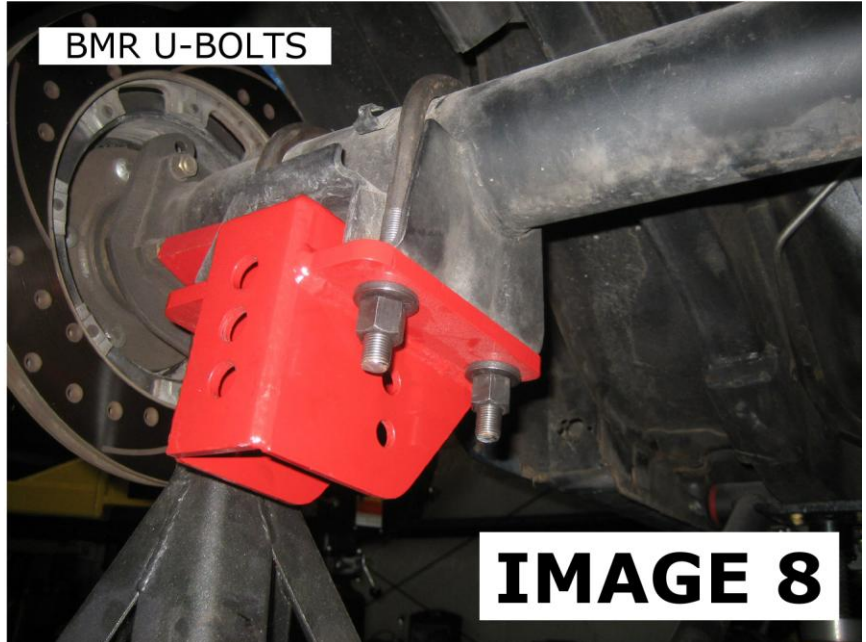
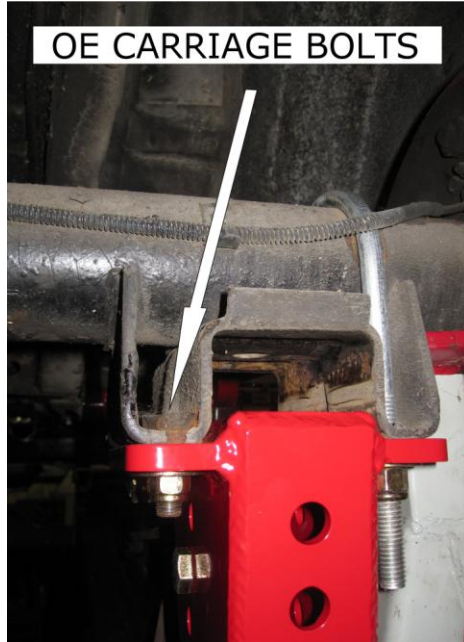

TAS010 TORQUE ARM CONVERSION INSTALLATION INSTRUCTIONS (*Continued*)

17. The next step involves installation of the shock cross-member. This step can be performed by one person but is much simpler with a helper. Have a helper hold the shock cross-member up into place as shown in **IMAGE 9**.

18. Use the fuel tank strap mounting positions as a reference point to locate the cross-member properly forward to back and to insure that the cross-member is mounted square in the body. As shown in **IMAGE 10**, measure the distance from the relief in the trunk pan to the main cross tube of the cross-member. Vehicle production variance prevents a “one measurement fits

all” figure but the measurements should fall somewhere between 3-7/8” to 4-1/8”, targeting 4” if possible. Re-position the cross-member until the reading from each strap mount relief is equal and falls within the range listed above.

19. Once properly positioned, locate the provided sheet metal screws in the hardware pack. As shown in **IMAGE 11**, screw the cross-member into each frame rail to hold it into position for the upcoming steps. *NOTE: the cross-member should draw up tight against the frame rail. Any floor pan deformations that prevent the cross-member from fitting flush against the frame rail should be flattened for optimal fit.*

20. At this step the cross-member may be welded to the subframe or bolted. If bolting is preferred, proceed to step 22. If welding is preferred, remove the cross-member and prep it for welding by grinding the powdercoat off at the weld points. Remove all paint, undercoating and scale from the weld area on the subframe then re-install the cross-member. Weld a full 2” bead vertically on each end of the plate and at least 4 inches of weld horizontally on each side. Wire brush and paint the weld area with rust preventive paint. Proceed to step 28.





TAS010 TORQUE ARM CONVERSION INSTALLATION INSTRUCTIONS (*Continued*)

21. If bolting the cross-member into place, position the provided frame reinforcement plate as shown in **IMAGE 12**. Mark the frame at the center of the slot using a grease pencil or paint marker.
22. Center-punch the marks on the frame to provide a drill centerline.
23. The recommended (and easiest) way to drill through the frame rails is with a small $\frac{1}{4}$ " pilot bit then step up to a $\frac{1}{2}$ " bit. Using the pilot bit, drill through the frame rail as shown in **IMAGE 13**, taking extra care to angle the drill correctly before drilling through the other side of the frame rail. Once the $\frac{1}{4}$ " holes have been drilled, switch to the $\frac{1}{2}$ " bit and enlarge the holes. In most cases, the holes in the cross-member itself will "self-align" the drill bit, forcing the bit to center itself in the hole.
24. Once both $\frac{1}{2}$ " holes are drilled through the sub frame, it is necessary to enlarge the outer frame holes to $\frac{3}{4}$ " to allow insertion of the provided frame reinforcement inserts. Using either a $\frac{3}{4}$ " drill bit or a step bit (recommended), enlarge ***ONLY*** the outer holes in the frame rail. (**IMAGE 14**)

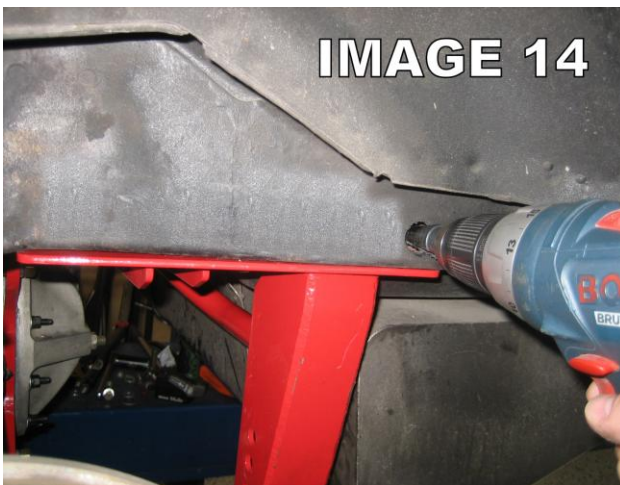

TAS010 TORQUE ARM CONVERSION INSTALLATION INSTRUCTIONS (*Continued*)

25. Assemble the outer reinforcement plate, frame inserts, and $\frac{1}{2}$ " x 3" bolts with stainless washers as shown in **IMAGE 15** on the previous page. Slide the assembly through the subframe until the bolts protrude through the BMR cross-member on the inside of the frame rail. Thread a nut and stainless washer onto the exposed portion of the bolts and then tighten to 80 ft/lbs.

26. Duplicate steps 21-26 for the other side of the vehicle.

27. At this point it is necessary to assemble the coil-over shocks for mounting. Refer to the shock manufacturer for proper coil-over assembly. Slide the upper mount of the shock into the BMR cross-member. Insert the supplied $\frac{1}{2}$ " x 2.5" bolt. Repeat for the other side. Place a stainless washer and nut onto the bolt and tighten to 80 ft/lbs.

28. Slide the upper mount of the shock into the BMR cross-member making sure the shock adjustment knobs (if any) are facing inward. Insert the supplied $\frac{1}{2}$ " x 2.5" bolt. Repeat for the other side. Thread a stainless washer and nut onto the bolt and tighten to 80 ft/lbs.

29. Assemble the bottom shock mount using the provided $\frac{5}{8}$ " x 4" bolt and aluminum mounting spacer. Place a $\frac{5}{8}$ " small diameter washer on either side of the poly bushings. Insert the bolt into one of the middle shock mounts located on the control arm mount.

NOTE: it may be necessary to raise or lower the rear end in order to insert the bolt. (**IMAGE 17**)

30. Place a large diameter washer over the $\frac{5}{8}$ " bolt inside the control arm mount and then thread a nut onto the bolt. Tighten to 80 ft/lbs.

31. Repeat steps 29-31 for the other side.

32. The next few steps involve mounting the Watts Link. Support the front of the rear end and loosen the large bolts that attach the torque arm to the rear differential mounting plate using a 1-1/8" socket. (**IMAGE 18** on previous page). Using a $\frac{3}{4}$ " wrench and socket, loosen the (4) $\frac{1}{2}$ " cross-bolts on the torque arm but do not remove them.

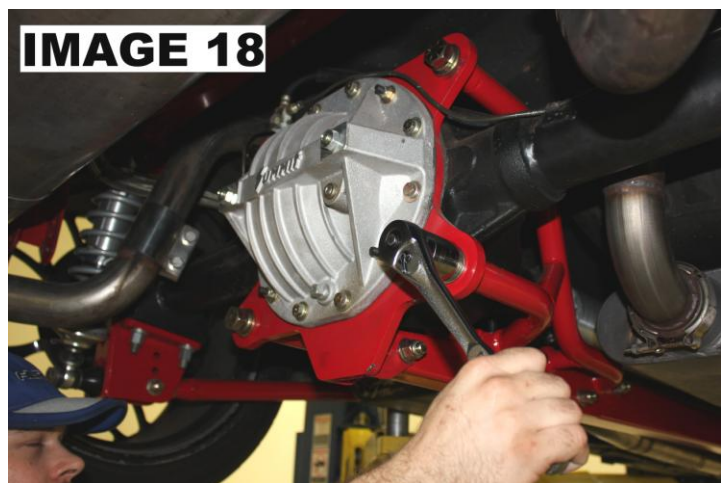

TAS010 TORQUE ARM CONVERSION INSTALLATION INSTRUCTIONS (*Continued*)

33. Install the BMR Watts Link mount as shown in **IMAGE 19**. Re-install and tighten the mounting bolts to 100 ft/lbs. Tighten the (4) 1/2" cross-bolts.
34. Locate the billet aluminum Watts pivot, the reinforcement plate, (2) 3/8" x 3.75" bolts, (2) 3/8" stainless washers, (2) 3/8" lock nuts, a 1/2" x 4" bolt, a 1/2" stainless washer, and a 1/2" lock nut. Refer to **IMAGE 19** and **20** for a visual representation of these components. *NOTE: If your vehicle will be setup for a low ride height, choose one of the lower sets of mounting holes to install the Watts pivot. For most applications, this is a good starting point. This mounting point determines the vehicles rear roll center (RC) height. Variances in vehicle center-of-gravity (CG) height necessitates multiple mounting locations for fine tuning RC height.*

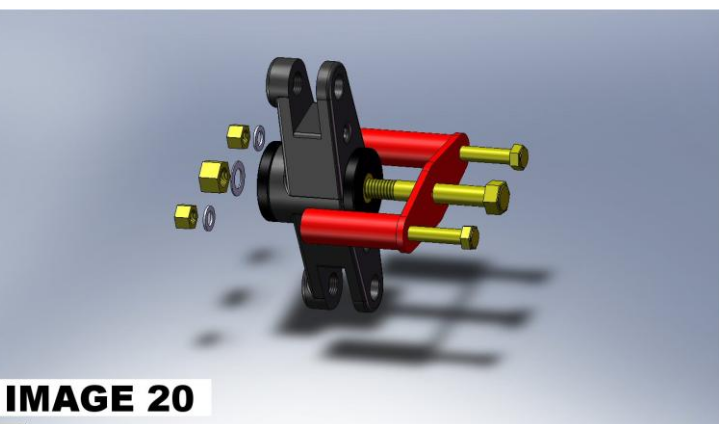

35. Tighten the center bolt to 80 ft/lbs. and the smaller outer bolts to 30 ft/lbs.
36. Before mounting the Watts link bars, it is necessary to load the vehicles suspension. Allow the weight of the vehicle to sit on the rear end and bounce the car a few times to settle the suspension. If the car sits too high or too low, use the provided spanner wrench at this time to adjust



the spring height on the shocks. If it is not possible to adjust the springs enough to achieve the desired ride height, move the lower shock mounting hole to a different location. Once the desired spring height is established, tighten the jam collar on the shock and proceed to the following step.



TAS010 TORQUE ARM CONVERSION INSTALLATION INSTRUCTIONS (*Continued*)

37. Using **IMAGE 21** on the previous page as a guide, thread one of the two Watts link bars onto the Watts link pivot and mount the other end into the drivers side mount. The bar should be installed into whichever mounting hole places the Watts link bar at the most level position while the suspension is loaded. Insert one of the provided ½” x 3.25” bolts. Thread a stainless washer and nut over the exposed thread and tighten to 80 ft/lbs.

NOTE: *the Watts link pivot should be vertical (straight up and down) with the suspension loaded. It will be necessary to adjust the rod end in order to achieve this.*

38. Duplicate the previous step for the passenger side Watts link bar.
39. As shown in **IMAGE 22**, use a plumb bob to determine proper axle location. **NOTE:** *it is not necessary to remove the wheels and tires to accomplish this, the measurement can also be taken from the wheel itself.* Hold the plumb bob against each wheel well in the same position and measure the axle location in relation to the fender. Adjust the rod ends until each side is equal while the Watts link pivot remains vertical (not angled).

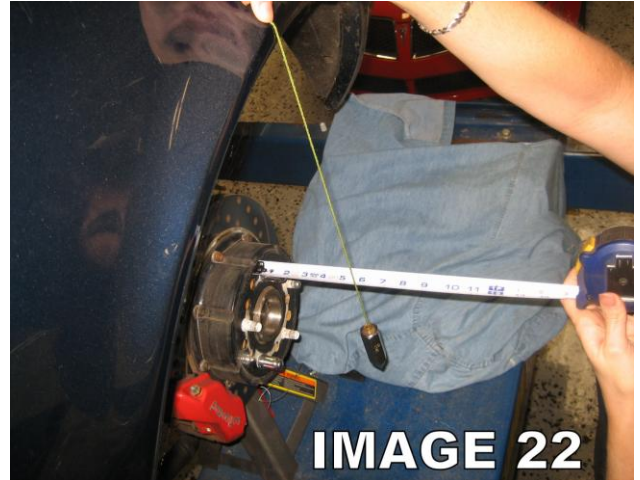

- Once all adjustments have been made, tighten all mounting bolts and then tighten the rod end jam-nuts on the Watts link bars.
40. Except for final setup, the installation is complete. Double-check all mounting bolts for tightness and inject a few pumps of grease into all of the grease fittings using the supplied silicone based lube. Re-grease the fittings initially after a few miles and then every other oil change thereafter.
41. Re-install the fuel tank and plumb the fuel lines.

SETTING UP YOUR NEW TORQUE ARM SUSPENSION

- Ride Height.** The very first thing that should be done is to establish the desired ride height. Previously the height was determined when the Watts link was setup during the installation process. Most of the time, this setting will be fine however driving the car will settle the suspension slightly and best determine if the height will need to be altered. Drive the car 10-20 miles to insure a consistent ride height and verify suspension travel. **NOTE:** *the suspension should not bottom out except in extreme road irregularities or very heavy dips. It is important to make sure the shocks do not bottom out to insure long shaft seal life. If you are out of spring adjustment and the suspension is still bottoming out, try changing the lower shock mounting locations and re-adjusting the springs. This will give more shock travel and increase the spring tension. In some circumstances with heavier vehicles, it may be necessary to increase the spring rate. In this case, please contact BMR for technical help in selecting proper rates.*
- Trailing Arm Angles.** With the final vehicle height determined, check the trailing arm angles. For proper anti-squat, the trailing arms, when viewed from the side of the car,



TAS010 TORQUE ARM CONVERSION INSTALLATION INSTRUCTIONS (*Continued*)

should angle upward slightly from rear to front (front mount higher than rear mount). If they are level or angled oppositely, lower the rear mounting point. This angle helps determine weight transfer upon acceleration. Each vehicle, depending on front-to-rear weight distribution will vary slightly and favor a “sweet” spot but a slightly upward angle of 1-2 degrees generally is optimal.

3. **Driveline angle.** Driveline angle should not have changed however, for long u-joint life and a quieter driveline it is important to make sure. If the angle is more than 2-3 degrees, refer to the BMR torque arm instructions for the proper adjustment procedure.
4. **Shock settings.** An entire book could be written on this subject but we will just touch on the basics. A lot of shocks have adjustments for both compression and rebound. It is important to understand that a shocks job is to control the motion of the spring. For optimal control, you never want the spring to collapse or extend too quickly. Determining those settings will differ for everybody since vehicle corner weights, desired ride quality, driving behavior, etc. play a role in finding what is optimal for that particular individual. It is generally best to start with softer settings and work your way up. The idea is to keep the tire firmly planted to the asphalt. Too much of either adjustment will not only create a harsh ride but will force the tires to bounce and lose traction during aggressive driving. The following recommendations are very basic and intended for street driving. Begin with the compression settings at full soft and the rebound settings two clicks from zero. Drive the car over varying road conditions and work your way up to a setting that feels firm yet still comfortable without excessive bounce over road irregularities. Once the rebound is set, begin adjusting the compression until ride quality begins to suffer then back a click. These settings should provide good all-around handling and ride quality, further adjustment may be necessary for very aggressive driving habits such as road course and autocross racing.
5. **Roll Center (Watts Link Height).** Roll center (RC) works in conjunction with the vehicles center-of-gravity (CG) height. Front RC also plays a role in determining an optimal rear RC since too much variance between the two can result in unpredictable and sudden body roll. Since both of these factors vary from car-to-car, finding the ideal setting will be different for everyone. The difference between the RC and the CG height determines the amount of weight shift (body roll) when cornering. The center hole on the Watts Link mount is a good place to start since it relates to the exact center of the axle. If the vehicle has been lowered excessively, it may be beneficial to begin in one of the lower mounting holes. Find a place for testing where you can aggressively drive around a corner consistently. Try a few settings up and down and choose the one that produces the least amount of body roll.
6. **Alignment.** Once all the above settings have been decided, the vehicle should have a 4-wheel alignment. This will insure that the rear end is square in the chassis.

If additional help is necessary with the installation or setup of this kit, please call BMR Suspension at 813-986-9302 or email GMTech@bmrsuspension.com.

WWW.BMRSUSPENSION.COM

This product is an aftermarket accessory and not designed by the vehicles manufacturer for use on this vehicle. As such, buyer assumes all risk of any damage caused to vehicle/person during installation or use of this product.