



**CAH756 – S197 Rear Upper Control Arm Hardware Upgrade Kit (5/8 Oversized Hardware)
For use with BK079 (Spherical Differential Bearing) ONLY!**

Tools Required:

- 15/16" Socket
- 15/16" Wrench
- 5/8" Drill Bit and Drill

Instructions:

- 1) This hardware upgrade kit **replaces** the **factory axle bolt** and **nut** on the axle of your rear upper control arm. This also replaces the **Aluminum Spacers** provided with the **BMR BK079 Spherical Differential Bearing Kit**.
- 2) Use a **5/8" Drill Bit** and enlarge the holes on your control arm to fit the 5/8" Bolt.
- 3) Using a washer under both the head of the hex screw and the nut, use a **15/16" socket** and **wrench** to torque fastener to **185ftlbs**.

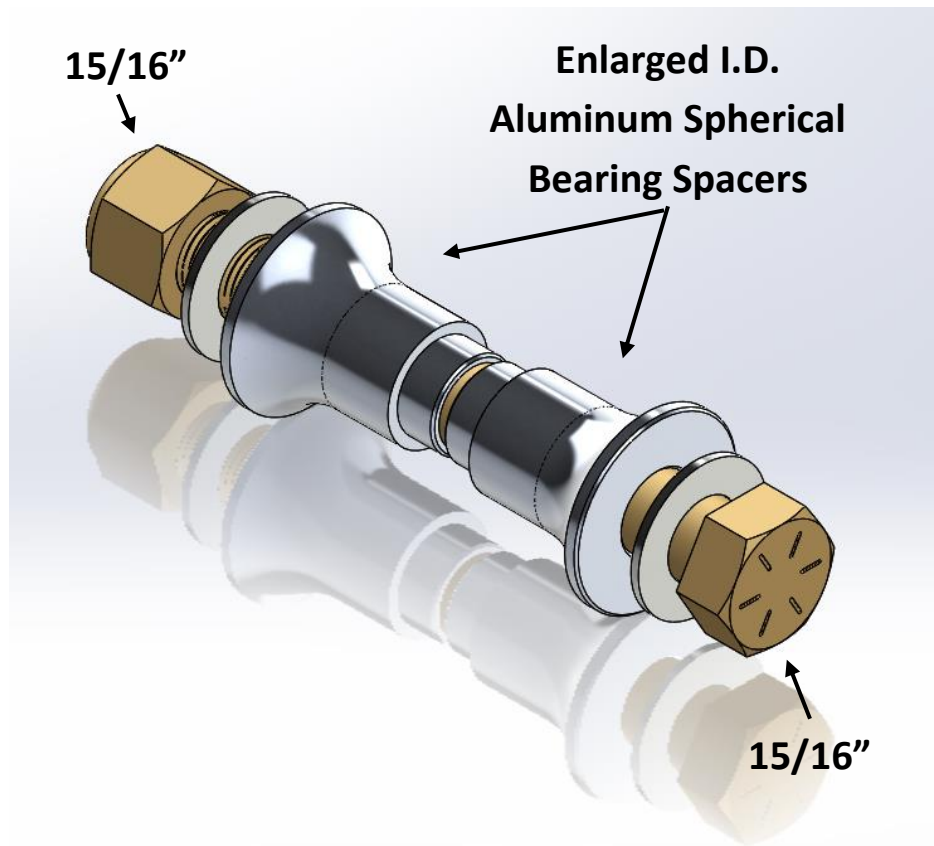

WWW.BMRSUSPENSION.COM

This product is an aftermarket accessory and not designed by the vehicles manufacturer for use on this vehicle. As such, Buyer assumes all risk of any caused to the vehicle/person during installation or use of this product.